

# PROGRAMING MANUAL FOR DM TUBULAR MOTORS M SERIES

Failure to comply with this Manual may result in injury or death. Keep the Manual for reference.

## 1. TECHNICAL SPECIFICATIONS



Power supply: 230 VAC / 50 Hz  
Limit switches: mechanical  
Operating temperature: ~ -25°C - ~ +50°C  
Protection degree: IP44

Company reserves the tolerance of catalog data due the different conditions usage.

## 2. ELECTRICAL CONNECTIONS

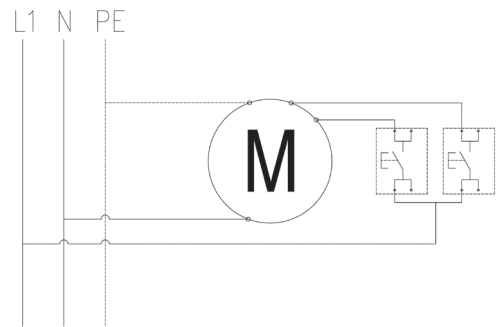
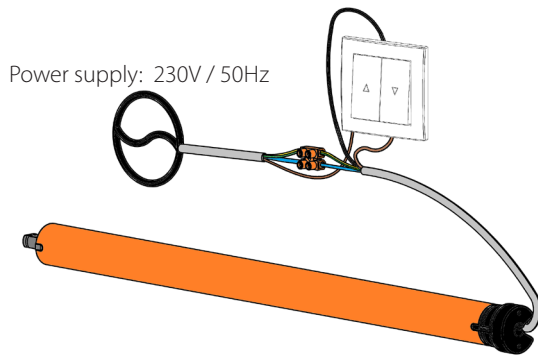

### NOTE

- Installation of the motor should be carried out by authorized persons.
- The motor is designed for use in dry rooms and should not be exposed to direct weather conditions.
- The motor should be powered by a separate circuit and protected by a quick fuse for example: circuit breaker type B10



In accordance with the provisions of the Directive of the European Parliament and of the Council 2012/19 / EU of 4 July 2012 on waste electrical and electronic equipment (WEEE), it is prohibited to place of used equipment together with other wastes, marked with crossed out wheeled bin symbol. The users are obliged to transfer their used equipment to a designated collection point for proper processing. The marking means, at the same time, that the equipment was put on the market after 13 August 2005. These legal obligations have been introduced to reduce the amount of waste generated from waste electrical and electronic equipment and to ensure an appropriate level of collection, recovery and recycling. The equipment does not contain any dangerous components, which would have any particularly negative impact on the environment and human health.



### 3. SETTING THE LIMIT SWITCHES

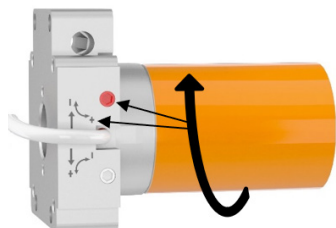

1. Start the closing mode of the shutter until it stops in the requested position (if the roller shutter is fully closed and the motor is still working, it should be stopped and proceed to step 3).
2. Turn the knob (marked ↑) in the (+) direction until required position of the shutter is reached.
3. If required position is exceeded raise the shutter and turn the knob few times in the (-) direction and repeat the procedure from first point.

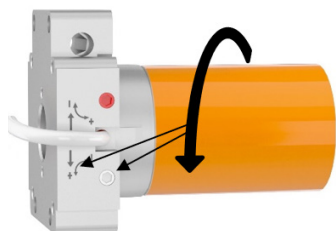

1. Start the roller shutter in opening direction until it stops in the end position (if the roller shutter is still opening it should be stopped and proceed to step 3).
2. Turn the knob (marked ↓) in the (+) direction until required position of the shutter is reached.
3. If the requested position is exceeded lower the shutter and regulate the knob in the (-) direction and repeat the procedure from step 1.